

---

---

# MITSUBISHI SEWING MACHINE PARTS CATALOG

Model.....DY-253

## INDEX

1.本体部分	.....Arm bed	.....G23- 1
2.針棒、天びん部分	.....Needle bar & thread take up lever mechanism	.....G23- 5
3.上軸部分	.....Upper shaft mechanism	.....G23- 7
4.縦軸部分	.....Vertical shaft mechanism	.....G23- 9
5.カマ、送り機構	.....Rotating hook & feed mechanism	.....G23-11
6.下軸部分	.....Lower shaft mechanism	.....G23-13
7.上部送り機構	.....Upper feed mechanism	.....G23-15
8.返し縫い機構	.....Reverse lever mechanism	.....G23-17
9.押エ上げ機構	.....Presser foot mechanism	.....G23-21
10.給油機構	.....Oil lubrication mechanism	.....G23-23
11.付属品	.....Accessories	.....G23-25

 **MITSUBISHI ELECTRIC CORPORATION**

---

---

197711

From the library of: Superior Sewing Machine & Supply LLC

DY-253形 機構図 TOTAL ASSY,

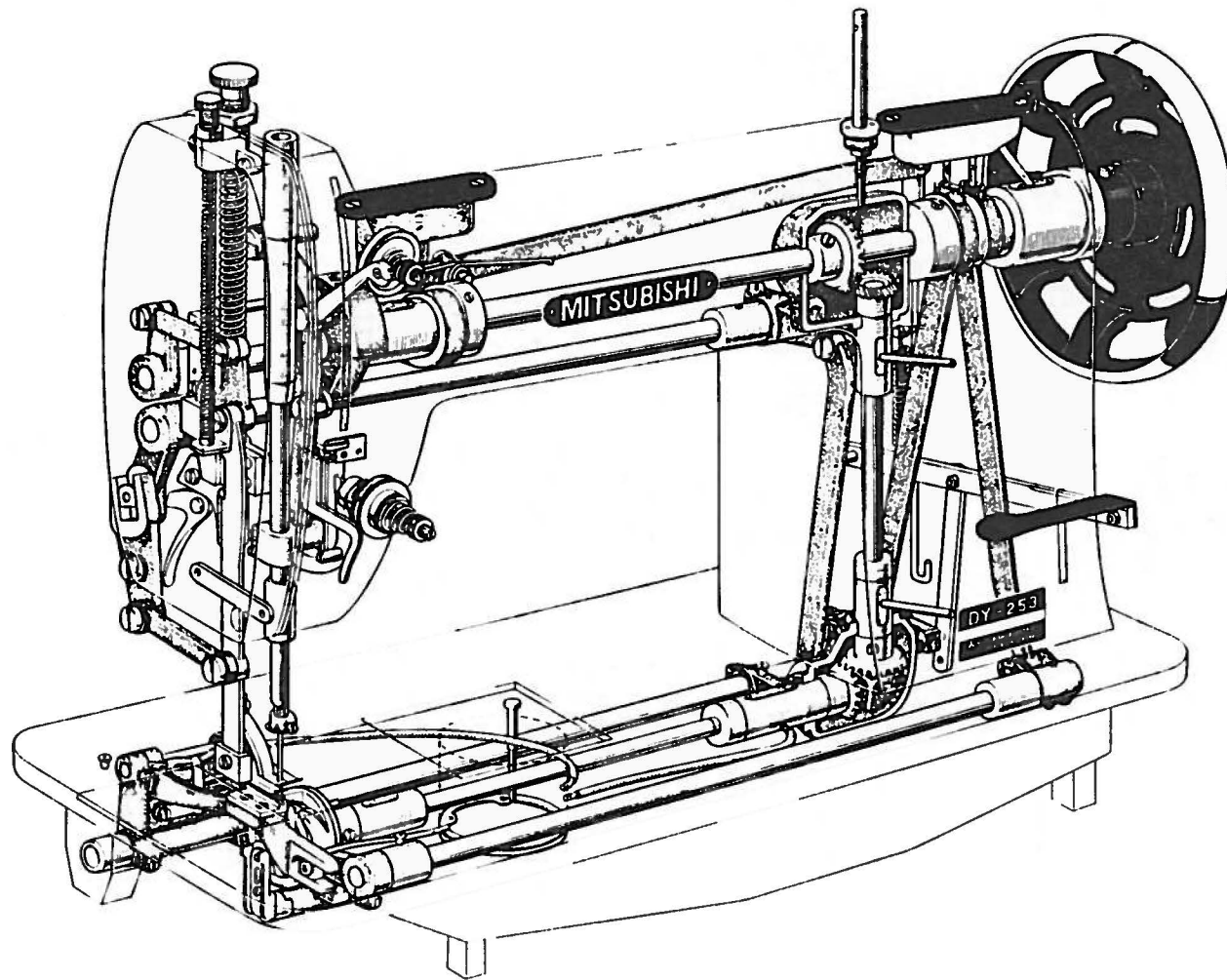

DY-253形 本体部分 ARM BED

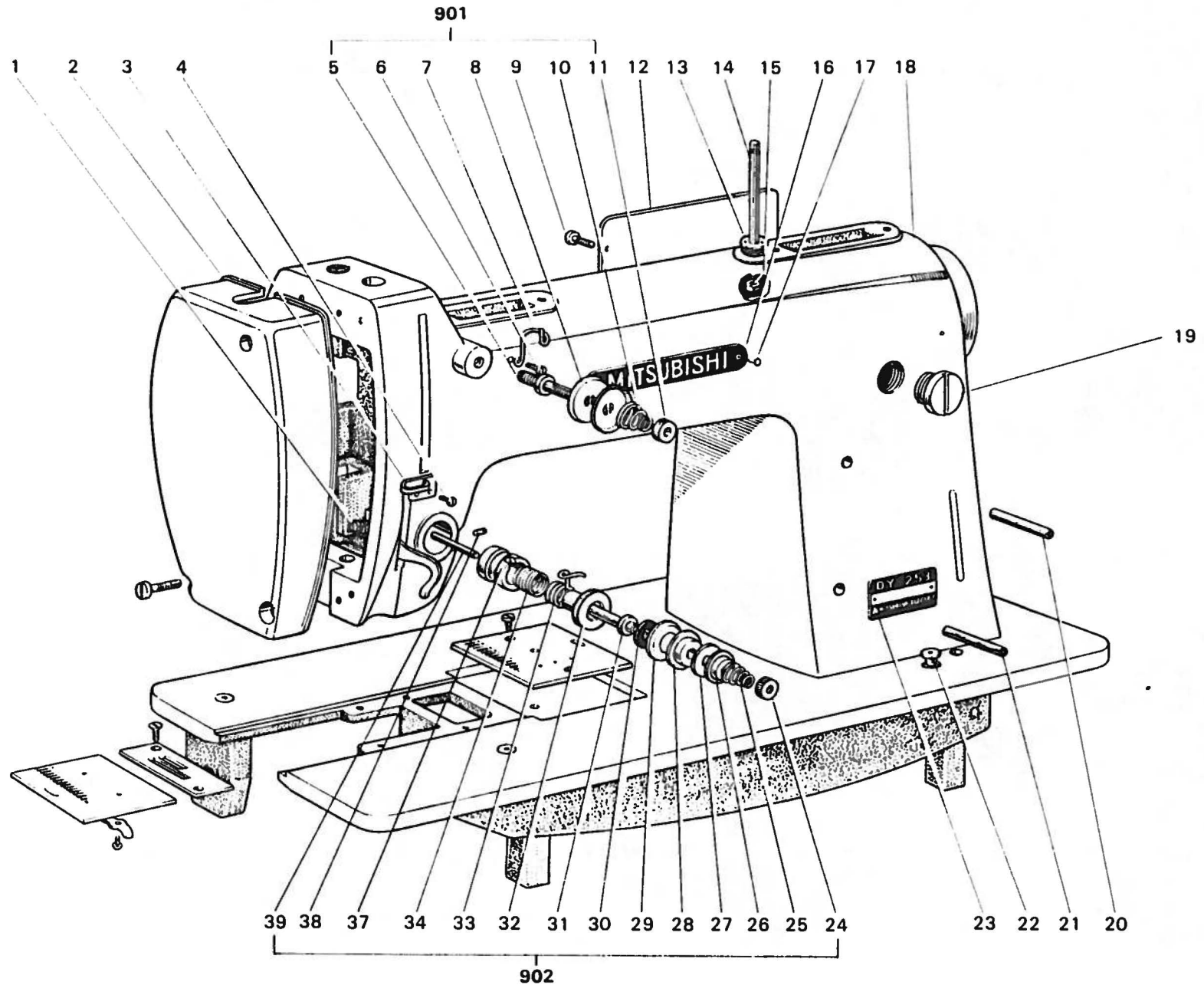



<DY-253形> 本体部分 ARM BED

Fig. No.	サービス部品コード Part No.	資材コード Code No.	部 品 名	Name of Part	個 / 台 Amt. req						備 考 Remarks
1	M9 1110 002	W500294	平 ネ ジ 11/64(40)×8	Screw							
2	MG 23C0 830	W220613-01	面 板	Face plate							
3	MG 23C0 181	W461009-01	糸カケ(アーム中)	Arm thread guide(middle)							
4	M9 1103 011	W502941	丸 皿 ネ ジ 11/64(40)×7	Screw for Fig.3							
901	MG 23C1 210	W456596	副上糸調節器(組)	Sub upper thread tension regulator assembly							
5	MG 23C0 553	W502017	糸 調 子 棒(後)	Tension stud							Fig.No.901ニ含ム
6	M9 1109 002	W500511	平 ネ ジ 11/64(40)×7	Screw for Fig.7							
7	MG 23C1 181	W461022	糸カケ(アーム上)	Arm thread guide(upper)							
8	MG 23C0 555	W502732	調 子 皿	Tension disc							Fig.No.901ニ含ム
9	M9 1110 002	W500294	平 ネ ジ 11/64(40)×8	Screw for Fig.12							
10	MG 23C0 245	W502733	糸 調 子 バ ネ	Tension spring							Fig.No.901ニ含ム
11	M9 1604 046	W501027-02	糸 調 子 ナ ッ ト 1/4(40)	Tension regulating thumb screw							"
12	MG 23C0 880	W459356-01	横 ブ タ	Arm side cover							
13	MG 23C0 188	W502793	糸 立 台	Thread spool stand							
14	MG 23C0 186	W459374-01	糸 立 棒	Thread spool pin							
15	M9 1105 045	B 503845	ナ ッ ト 11/64(40)×5	Nut							
16		W450620	社 名 板	Name plate							
17	M9 5001 062	W461746	ネ ジ ビ ヨ ウ	Screw for Fig.16							
18			アームベッド(組)	Arm bed assembly							
19	M9 5401 002	W460506	平 ネ ジ M22×18	Screw							
20	MG 23C0 143	W502925-01	油 管(上)	Oil pipe(upper)							
21	MG 23C0 144	W502925-02	油 管(下)	Oil pipe(lower)							
22	MF 60A0 251	W469101	オイルカップ	Oil cap							
23		W451064-47	形 名 板	Model plate							
902	MG 23C0 210	W456591	上糸調節器(組)	Upper thread tension regulator assembly							
24		W501027-02	糸 調 子 ナ ッ ト	Tension regulating thumb nut							Fig.No.902ニ含ム
25	MG 23C1 557	W461079-1	糸 調 子 バ ネ	Tension releasing lever spring							"
26	MG 23C0 556	W461065	皿 押 エ	Tension releasing disc							"
27		W502707	座	Tension washer							"
28	MG 23C1 555	W502709	調 子 皿	Tension disc(2)							"
29	MG 23C2 555	W502708	調 子 皿	Tension disc(1)							"
30		W502716	フ ェ ル ト	Washer(felt)							"
31	MG 23C1 553	W456592-01	調 子 棒	Tension screw stud							"
32		W502710	調 節 ブ ッ シ ュ	Tension regulating bushing							"
33	MG 23C0 187	W456593-01	糸 取 リ バ ネ	Tension spring							"
34	MG 23C0 557	W456597-01	ネジリコイルバネ	Spring							"
37		W456594-01	ブ ッ シ ュ	Tension regulating bushing							"
38	M9 1508 001	B 509088	頭ナシ止メネジ 15/64(28)×8	Screw							
39		W502388-03	糸ユルメピン	Tension releasing pin							Fig.No.902ニ含ム



DY-253形 本体部分 ARM BED

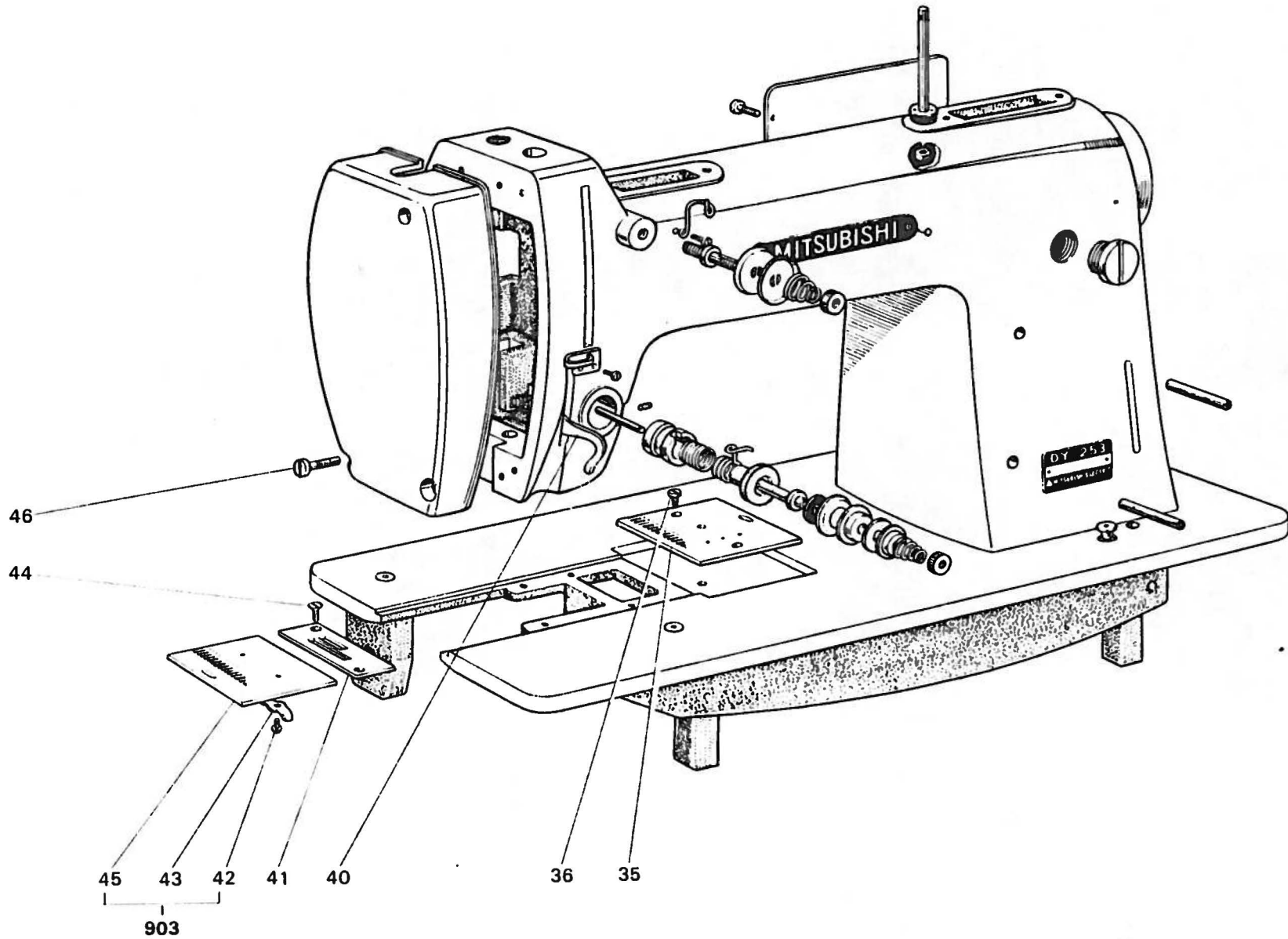





DY-253形 針棒、天びん部分 NEEDLE BAR & THREAD TAKE UP  
LEVER MECHANISM

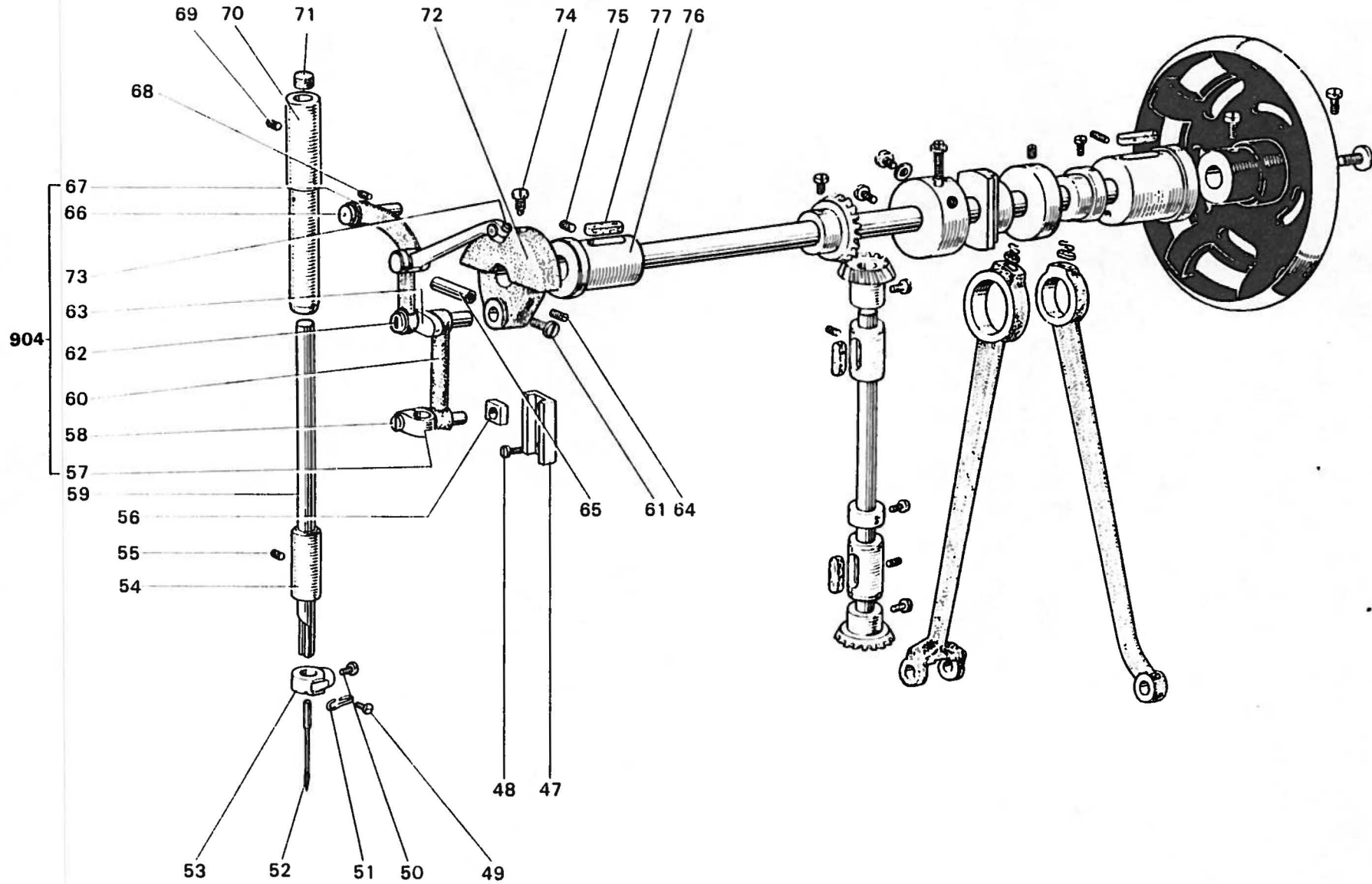

<DY-253形> 針棒、天びん部分 NEEDLE BAR & THREAD TAKE UP LEVER MECHANISM

Fig. No.	サービス部品コード Part No.	資材コード Code No.	部 品 名	Name of Part	個 / 台 Amt. req					備 考 Remarks
47	MG 23C0 662	W456582-01	針棒クランクガイド	Needle bar crank guide						
48	M9 1110 002	W500294	平 ネ ジ 11/64(40)×8	Set screw for Fig.47						
49	M9 0906 002	W500791	平 ネ ジ 9/64(40)×4.5	Set screw for Fig.51						
50	M9 1501 003	B 508963	丸 平 ネ ジ 15/64(28)×10	Set screw for Fig.53						
51	MG 23C2 181	W502730	糸カケ(針止メ用)	Needle clamp thread guide						
52		W465212	針 DD×1 #25	Needle DD×1(#25)						
53	MG 23C0 679	W456584	針 止 メ	Needle clamp						
54	MG 23C0 664	W502705	針棒メタル(下)	Needle bar bushing(lower)						
55	M9 1108 001	B 503846	頭ナシ止メネジ 11/64(40)×5.5	Set screw for Fig.54						
56	MG 23C0 325	W502717	角 駒	Needle bar connecting block						
904	MG 23E0 582		天 ビ ン(組)	Thread take up lever assembly						
57		W456581-01	針 棒 ダ キ	Needle bar holder						Fig.No.904ニ含ま
58	M9 1251 002	W20466-A	平 ネ ジ 3/16(32)×12	Set screw for Fig.57						"
59	MG 23C0 660	W456580-01	針 棒	Needle bar						
60		W456583-01	針棒クランクロット	Needle bar connecting link						Fig.No.904ニ含ま
61	M9 1210 002	W501247	平 ネ ジ 3/16(28)×10	Set screw for Fig.72						
62	M9 1181 003	W502725	丸 平 ネ ジ(左) 11/64(40)×13.5	Set screw for Fig.59						Fig.No.904ニ含ま
63		W456588-01	天ビンクランク	Thread take up lever link						"
64	M9 2001 001	W502218	頭ナシ止メネジ 5/16(24)×8	Set screw for Fig.72						
65	M9 0511 063	W502731	特 殊 ビ ン	Thread take up lever hinge pin						
66		W502706	天ビン支工軸	Thread take up lever link hinge pin						Fig.No.904ニ含ま
67		W456585	天 ビ ン	Thread take up lever						"
68	M9 1513 001	B 509060	頭ナシ止メネジ 15/64(28)×11	Set screw for Fig.70						
69	M9 1106 001	B 509266	頭ナシ止メネジ 11/64(40)×4.3	Set screw for Fig.70						
70	MG 23C0 663	W456579-01	針棒メタル(上)	Needle bar bushing(upper)						
71	MG 23C0 740	W502203	フ ェ ル ト	Felt						
72	MG 23C0 383	W456589-01	ク ラ ン ク	Needle bar crank						
73	M9 0601 002	W502723	平 ネ ジ 3/32(52)×6	Set screw for Fig.72						Fig.No.904ニ含ま
74	M9 1802 006	B 503851	棒 先 平 ネ ジ 9/32(28)×14	Set screw for Fig.72						
75	M9 1513 001	B 509060	頭ナシ止メネジ 15/64(28)×11	Set screw for Fig.76						
76	MG 23C0 232	W45 659-01	上軸メタル(左)	Arm shaft bushing(left)						
77	MG 23C1 740	W502486	フ ェ ル ト	Felt						



DY-253形 上軸部分 UPPER SHAFT MECHANISM

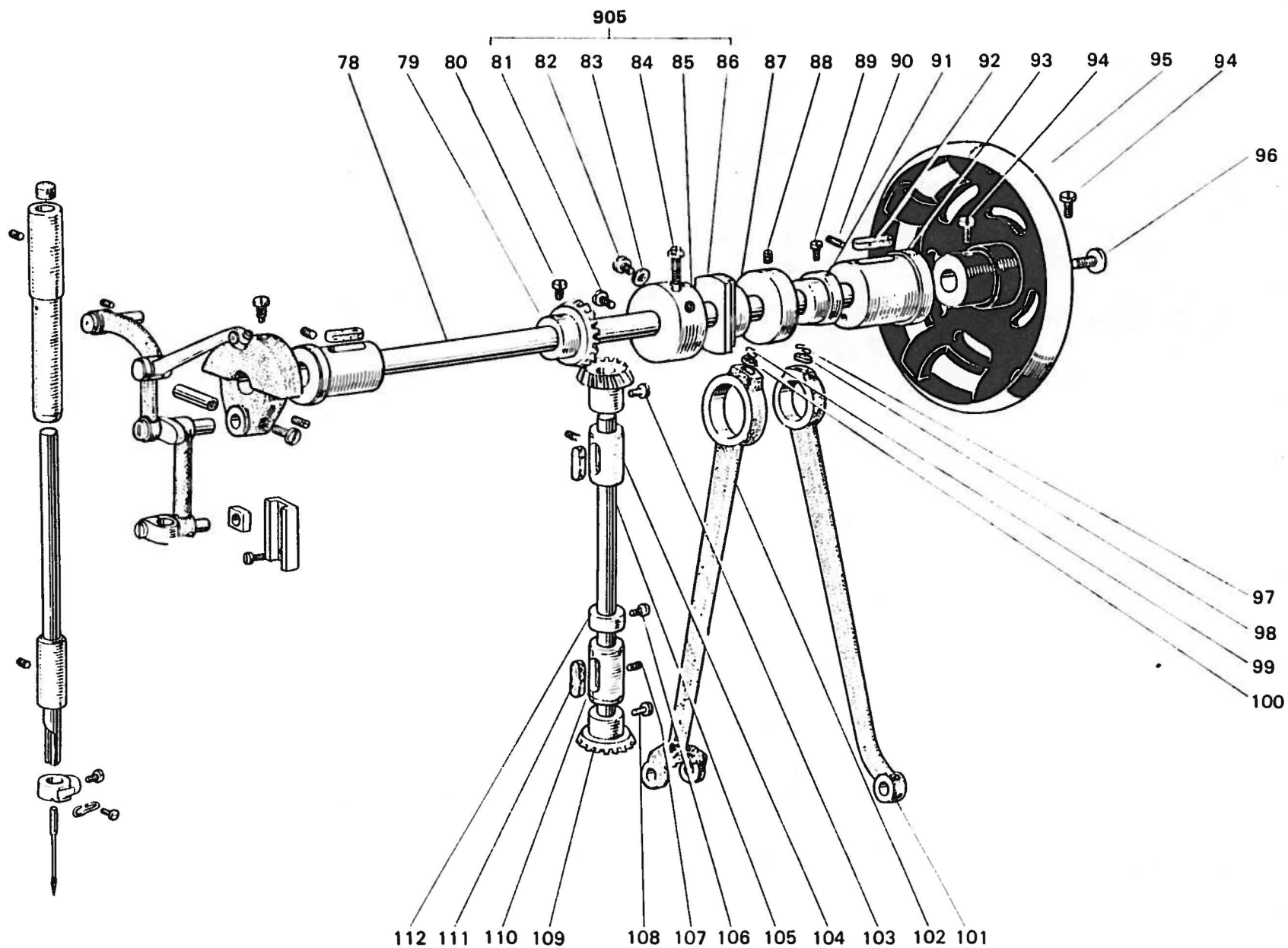

<DY-253形> 上軸部分 UPPER SHAFT MECHANISM

Fig No	サービス部品コード Part No.	資材コード Code No.	部 品 名	Name of Part	個 / 台 Amt. req					備 考 Remarks
78	MG 23C0 230	W322765-01	上 軸	Arm shaft						
79	MG 23C0 331	W456598-01	傘 歯 車(上軸)	Bevel gear for arm shaft						
80	M9 1602 002	W502703	平 ネ ジ 1/4(40)×9	Set screw for Fig.79						
905	MG 23E0 490		水平送り調節体(組)	Feed cam assembly						
81	M9 1107 002	W500092	平 ネ ジ 11/64(40)×5.5	Set screw for Fig.85						Fig.No.905ニ含ま
82	M9 1504 002	B 508963	平 ネ ジ 15/64(28)×10	Set screw for Fig.85						"
83		W465217	座 金	Washer for Fig.82						"
84	M9 1203 004	W500442	水平送り調節ネジ 3/16(28)×24	Thumb screw for feed cam						"
85		W460576-01	水平送り調節体	Feed cam regulator						"
86		W460577-01	水平送りカム	Feed cam						"
87	MG 23C0 352	W459362	カ ラ ー	Collar						
88	M9 1516 001	W500006	頭ナシ止メネジ 15/64(28)×15	Set screw for Fig.87						
89	M9 1504 002	B 508963	平 ネ ジ 15/64(28)×10	Set screw for Fig.91						
90	M9 1513 001	B 509060	頭ナシ止メネジ 15/64(28)×11	Set screw for Fig.93						
91	MG 23C0 461	W459318-01	上下送りカム	Feed lifting cam						
92	MG 23C1 740	W502486	フ ェ ル ト	Felt						
93	MG 23C0 233	W459322-01	上軸メタル(右)	Arm shaft bushing(right)						
94	M9 1802 002	W462896	平 ネ ジ 9/32(28)×16	Set screw for Fig.95						
95	MG 23C0 682	W322766-01	ハ ズ ミ 車	Balance wheel						
96	M9 2202 003	W500246	丸 平 ネ ジ 11/32(28)×17	Set screw for Fig.95						
97	MF 60A0 700	W500836	バ ネ	Spring for Fig.98						
98	MG 23C2 740	W500738-02	フ ェ ル ト	Felt for Fig.101						
99	MF 60A0 700	W500836	バ ネ	Spring for Fig.100						
100	MG 23C2 740	W500738-02	フ ェ ル ト	Felt for Fig.102						
101	MG 23C0 385	W322770-01	クランクロッド(上下)	Feed rock shaft connecting rod(front)						
102	MG 23C0 386	W322767-01	クランクロッド(水平)	Feed rock shaft connecting rod(back)						
103	M9 1602 002	W502703	平 ネ ジ 1/4(40)×9	Screw for Fig.115						
104	MG 23C0 521	W457538-01	縦軸メタル(上)	Feed lifting rock shaft bushing(upper)						
105	MG 23C0 520	W457501-01	縦 軸	Feed lifting rock shaft						
106	M9 1602 002	W502703	平 ネ ジ 1/4(40)×9	Screw for Fig.112						
107	M9 1513 001	B 509060	頭ナシ止メネジ 15/64(28)×11	Screw for Fig.110						
108	M9 1602 002	W502703	平 ネ ジ 1/4(40)×9	Screw for Fig.109						
109	MG 23C0 334	W457503-01	傘 歯 車(縦軸下)	Bevel gear(lower)						
110	MG 23C0 522	W459371-01	縦軸メタル(下)	Feed lifting rock shaft bushing(lower)						
111	MG 23C3 740	W500043-02	フ ェ ル ト	Felt						
112	MG 23C1 352	W502001-02	カ ラ ー	Collar						



DY-253形 豎軸部分 VERTICAL SHAFT MECHANISM

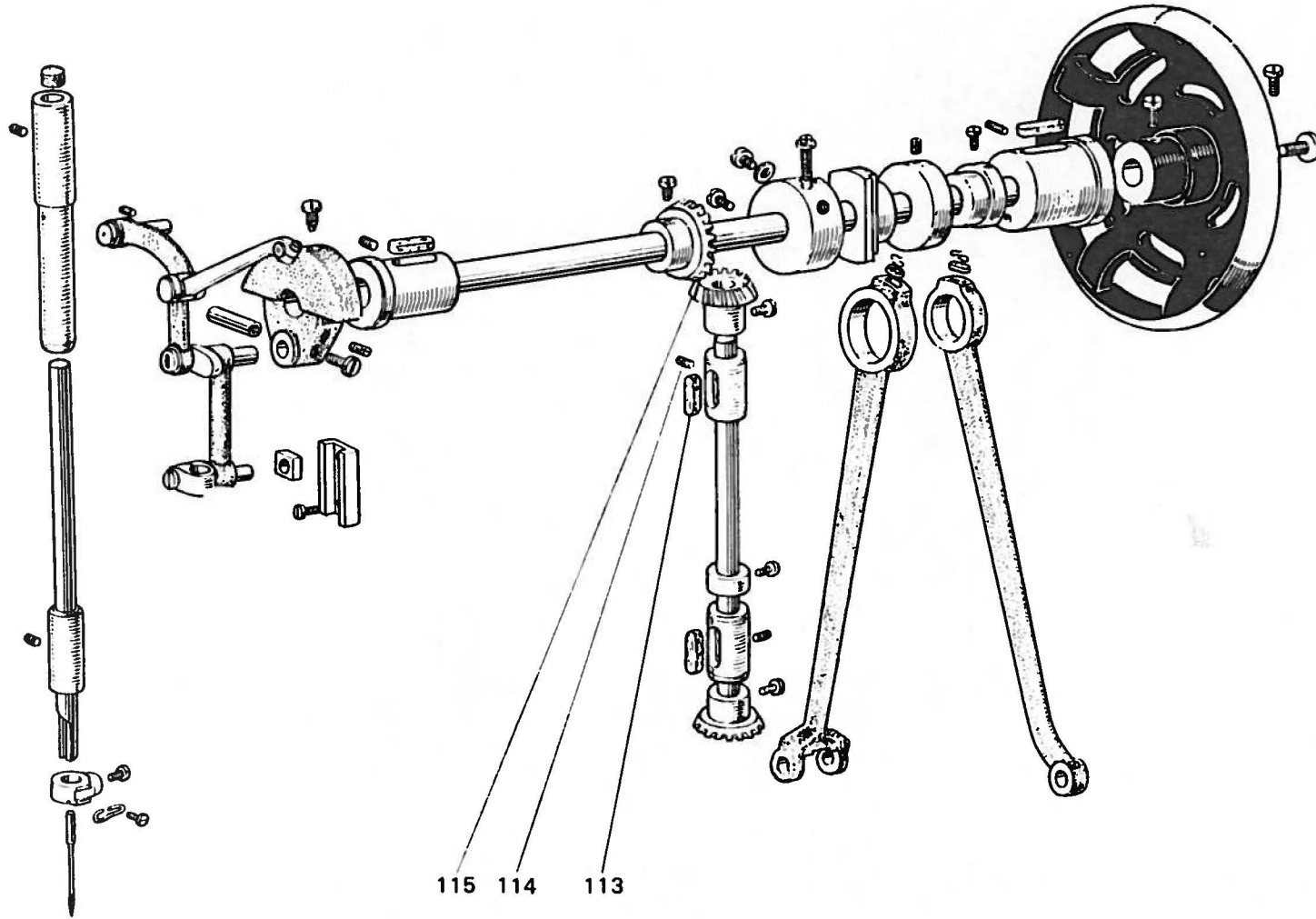





## DY-253形 カマ、送り機構 ROTATING HOOK &amp; FEED MECHANISM

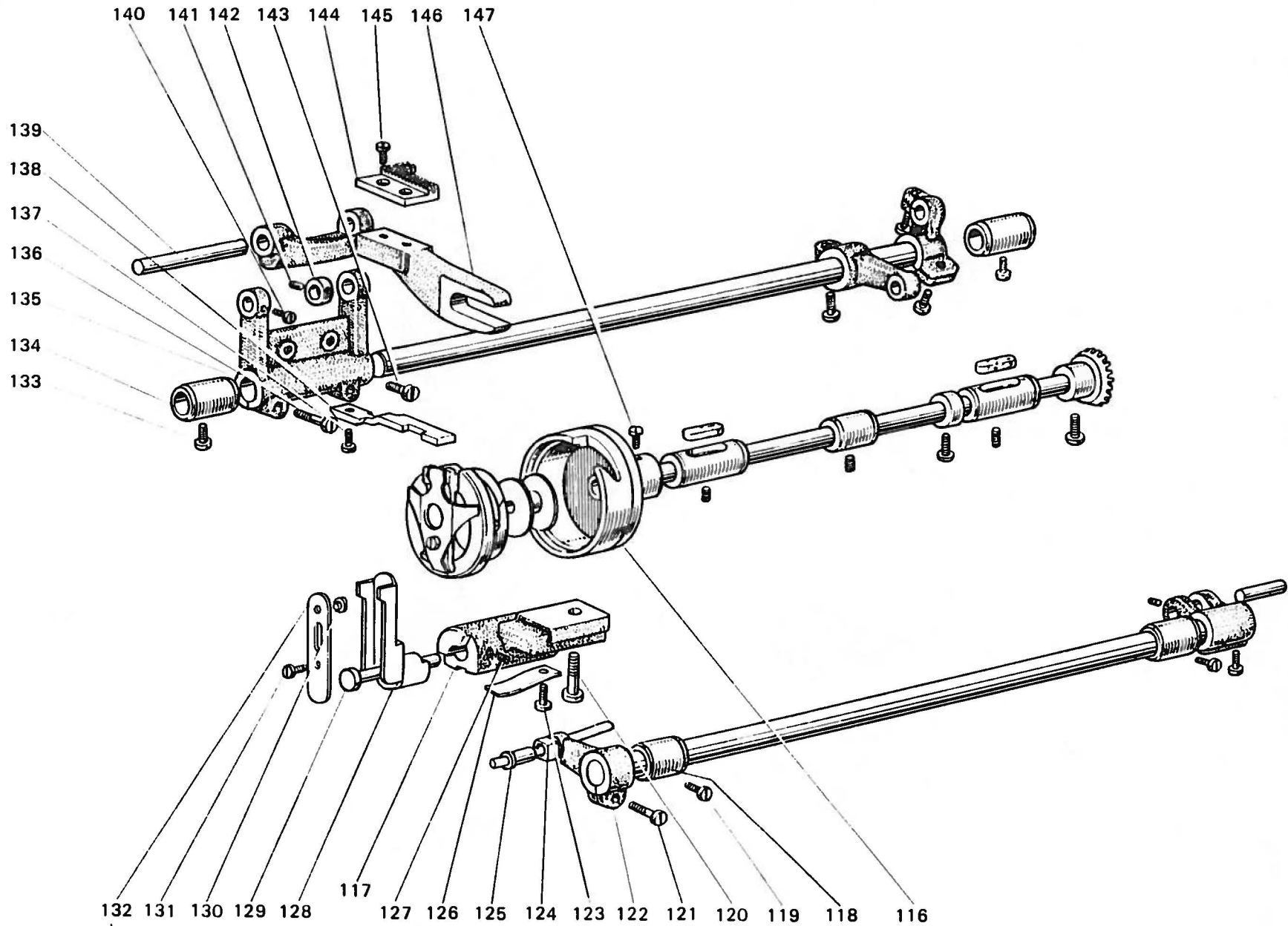

<DY-253形> カマ、送り機構 ROTATING HOOK & FEED MECHANISM

Fig. No.	サービス部品コード Part No.	資材コード Code No.	部 品 名	Name of Part	個 / 台 Amt. req					備 考 Remarks
116	MG 23E0 121		外 ガ マ(組)	Rotating hook assembly						
906	MG 23E0 616		カ マ 押 エ (組)	Rotating hook positioner assembly						
117	MG 23C0 781	W457544	カ マ 押 エ 台	Rotating hook positioner						Fig.No.906ニ含ム
118	MG 23C0 285	W457554-01	送 り 軸 メ タ ル	Feed lifting rock shaft bushing						
119	M9 1502 002	W500509	平 ネ ジ 15/64(28)×12	Screw for Fig.118						
120	M9 2051 003	W502313-02	丸 平 ネ ジ 5/16(24)×26	Screw for Fig.117						
121	M9 1505 002	W500183-01	平 ネ ジ 15/64(28)×14	Screw for Fig.122						
122	MG 23C0 276	W457520-01	送 り 腕 (上 下 左) (組)	Feed lifting rock shaft crank						
123	M9 1108 002	B 509289	平 ネ ジ 11/64(40)×7	Screw for Fig.126						Fig.No.906ニ含ム
124	MG 23C1 325	W449955-02	角 駒	Square block						Fig.No.122ニ含ム
125	M9 0606 063	W502057	コ ロ 軸	Square block set pin						"
126	MG 23C0 192	W502719	板 バ ネ	Spring						Fig.No.906ニ含ム
127	M9 1506 001	B 509087	頭 ナ シ 止 メ ネ ジ 15/64(28)×7	Screw for Fig.117						"
128	MG 23C0 257	W457545	カ マ 押 エ 腕	Rotating hook positioner crank						"
129	M9 0709 063	W502720	平 ピ ン	Set pin for Fig.128						"
130	M9 0402 063	W502721	カ シ メ ピ ン	Set pin for Fig.132						"
131	M9 0909 003	W501901	丸 平 ネ ジ 9/64(40)×6	Screw for Fig.132						"
132	MG 23C0 258	W457546	押 エ 板 バ ネ	Rotating hook positioner spring						"
133	M9 1502 002	W500509-02	平 ネ ジ 15/64(28)×12	Screw for Fig.134						
134	MG 23C0 285	W457554-01	送 り 軸 メ タ ル	Feed rock shaft bushing(left)						
135	MG 23C0 278	W459308-01	送 り 腕 (水 平、左)	Feed rock shaft crank(left)						
136	M9 1603 003	W501009	丸 平 ネ ジ 1/4(24)×16	Screw for Fig.135						
137	M9 1204 003	B 508978	丸 平 ネ ジ 3/16(28)×12	Screw for Fig.138						
138	MG 23C0 229	W457542-01	内 ガ マ 止 メ	Rotating hook positioner						
139	MG 23C0 283	W502779	送 り 台 支 エ 軸	Feed bar shaft						
140	M9 1108 002	B 509289	平 ネ ジ 11/64(40)×7	Screw for Fig.135						
141	M9 1506 001	B 509087	頭 ナ シ 止 メ ネ ジ 15/64(28)×7	Screw for Fig.146						
142	MG 23C2 352	B 422844-02	カ ラ ー	Collar for Fig.139						
143	M9 0906 002	W500791	平 ネ ジ 9/64(40)×4.5	Screw for Fig.135						
144	MG 23C0 104	W322769-01	送 り	Feed dog						
145	M9 0912 002	W500713	平 ネ ジ 9/64(40)×8.5	Screw for Fig.144						
146	MG 23C0 281	W322768-01	送 り 台	Feed bar						
147			カ マ セ ッ ト ネ ジ	Screw for Fig.116						Fig.No.116ニ含ム



DY-253形 下軸部分 LOWER SHAFT MECHANISM

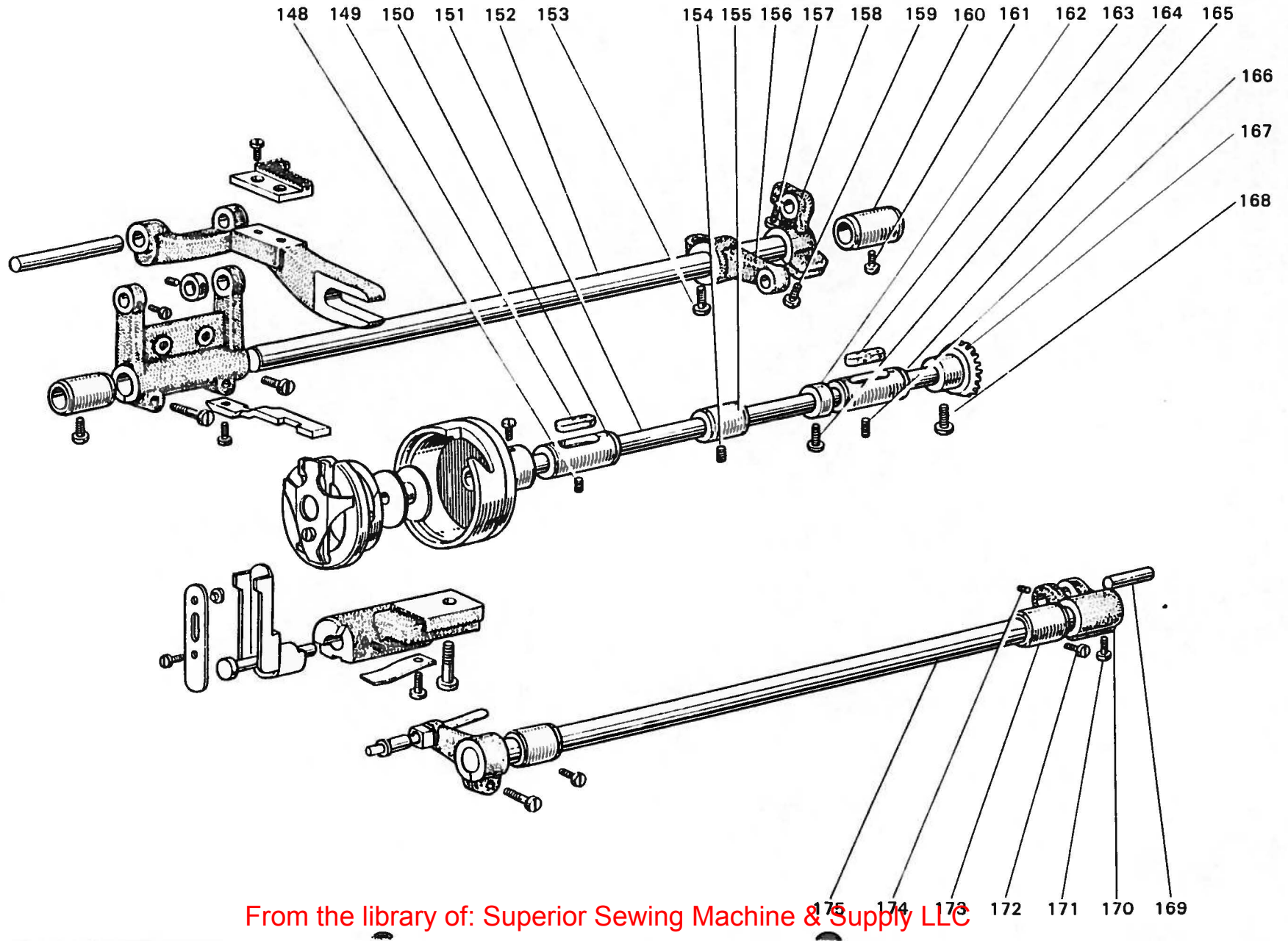





DY-253形 上部送り機構 UPPER FEED MECHANISM

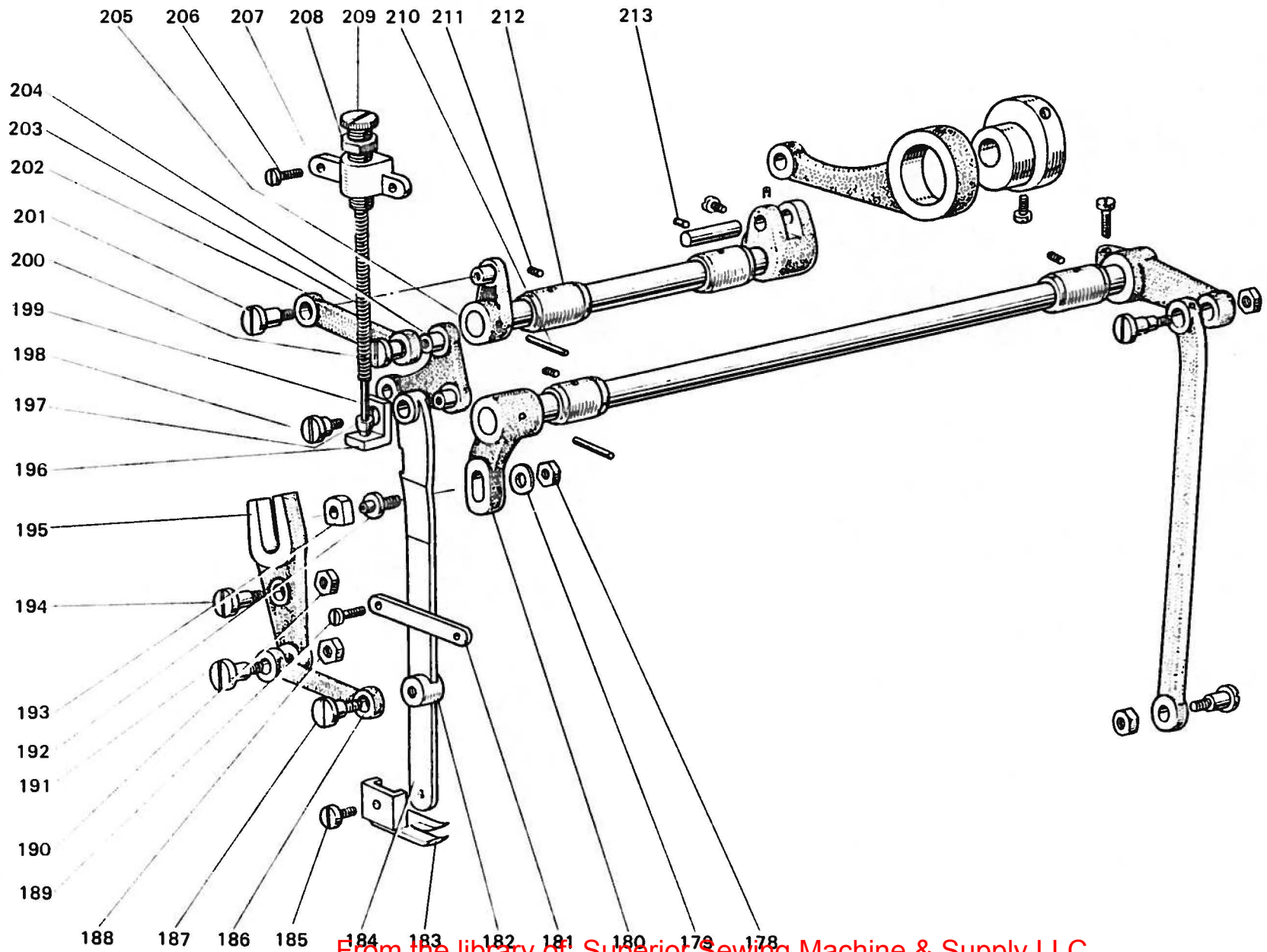

<DY-253形> 上部送り機構 UPPER FEED MECHANISM

Fig. No.	サービス部品コード Part No.	資材コード Code No.	部 品 名	Name of Part	個 / 台 Amt. req					備 考 Remarks
178	M9 1601 045	W501989	ナ ッ ト 1/4(24)×3.5	Nut for Fig.193						
179	M9 0607 050	W462759	座 金 M6	Washer for Fig.178						
180	MG 23C0 464	W464054	送り腕(上部水平左)	Feed rock shaft crank(left)						
181	MG 23C0 296	W502715	送り足支工案内	Walking foot guide link						
182		W502794	ブ ッ シ ュ	Walking foot guide bushing						
183	MG 23C0 294	W457549	送 り 足	Walking foot						
184	MG 23C0 295	W324527	送 り 足 支 エ	Walking foot guide supporter						
185	M9 1108 002	B 509289	平 ネ ジ 11/64(40)×7	Screw for Fig.183						
186	MG 1080 910	W457552-01	リ ン ク	Walking foot guide link						
187	M9 1602 015	W501245	段 付 平 ネ ジ 1/4(24)×18	Screw for Fig.186						
188	M9 1601 045	W501989	ナ ッ ト 1/4(24)×3.5	Nut for Fig.191						
189	M9 1110 002	W500294	平 ネ ジ 11/64(40)×8	Screw for Fig.181						
190	M9 1503 045	W501843	ナ ッ ト 15/64(28)×5.5	Nut for Fig.194						
191	M9 1602 015	W501245	段 付 平 ネ ジ 1/4(24)×18	Screw for Fig.186						
192	M9 5005 063	W464052	コ ロ 軸	Feed connecting rod						
193	MG 3080 411	W443980	コ ロ	Slide block						
194	M9 1507 015	W466842	段 付 平 ネ ジ 15/64(28)×23.5	Screw for Fig.195						
195	MG 23C0 950	W459317-01	レ バ ー	Feed connecting rod						
196	MG 23C0 226	W502714	受 ケ 金	Prop up washer Fig.199						
197		W502412	案 内 金	Bell crank pin clamp						Fig.No.199ニ含ム
198	M9 1213 015	W501569	段 付 平 ネ ジ 3/16(28)×14.5	Bell crank screw						
199	MG 23C0 157	W502712	案 内 棒	Bell crank pin						
200	M9 1210 002	W501247	平 ネ ジ 3/16(28)×10	Screw for Fig.202						
201	M9 1210 002	W501247	平 ネ ジ 3/16(28)×10	Screw for Fig.202						
202	MG 23C0 910	W457526	リ ン ク	Feed lifting rock shaft link						
203	MF 40A1 572	W446379-01	ツル巻キバネ	Bell crank spring						
204	MG 23C0 763	W457527-01	ベルクランク	Bell crank						
205	MG 23C0 462	W457525-01	送り腕(上部上下左)	Upper feed lifting rock shaft crank(left)						
206	M9 1110 002	W500294	平 ネ ジ 11/64(40)×8	Screw for Fig.207						
207	MG 23C0 261	W4575-01	押 エ 調 節 台	Presser regulating bracket						
208	M9 2402 045	B 509118	ナ ッ ト 3/8(28)×5	Nut for Fig.209						
209	M9 2401 035	W457536-01	調 節 ネ ジ 3/8(28)×50	Feed regulating thumb screw						
210	M9 0401 061	W501209	テ ー パ ー ピ ン 4φ×23×1/50	Taper pin for Fig.205						
211	M9 1508 001	B 509088	頭ナシ止メネジ 15/64(28)×8	Screw for Fig.212						
212	MG 23C1 285	W457554-02	送り軸メタル	Upper feed lifting rock shaft bushing(left)						
213	M9 1508 001	B 509088	頭ナシ止メネジ 15/64(28)×8	Screw for Fig.214						



DY-253形 上部送り機構 UPPER FEED MECHANISM

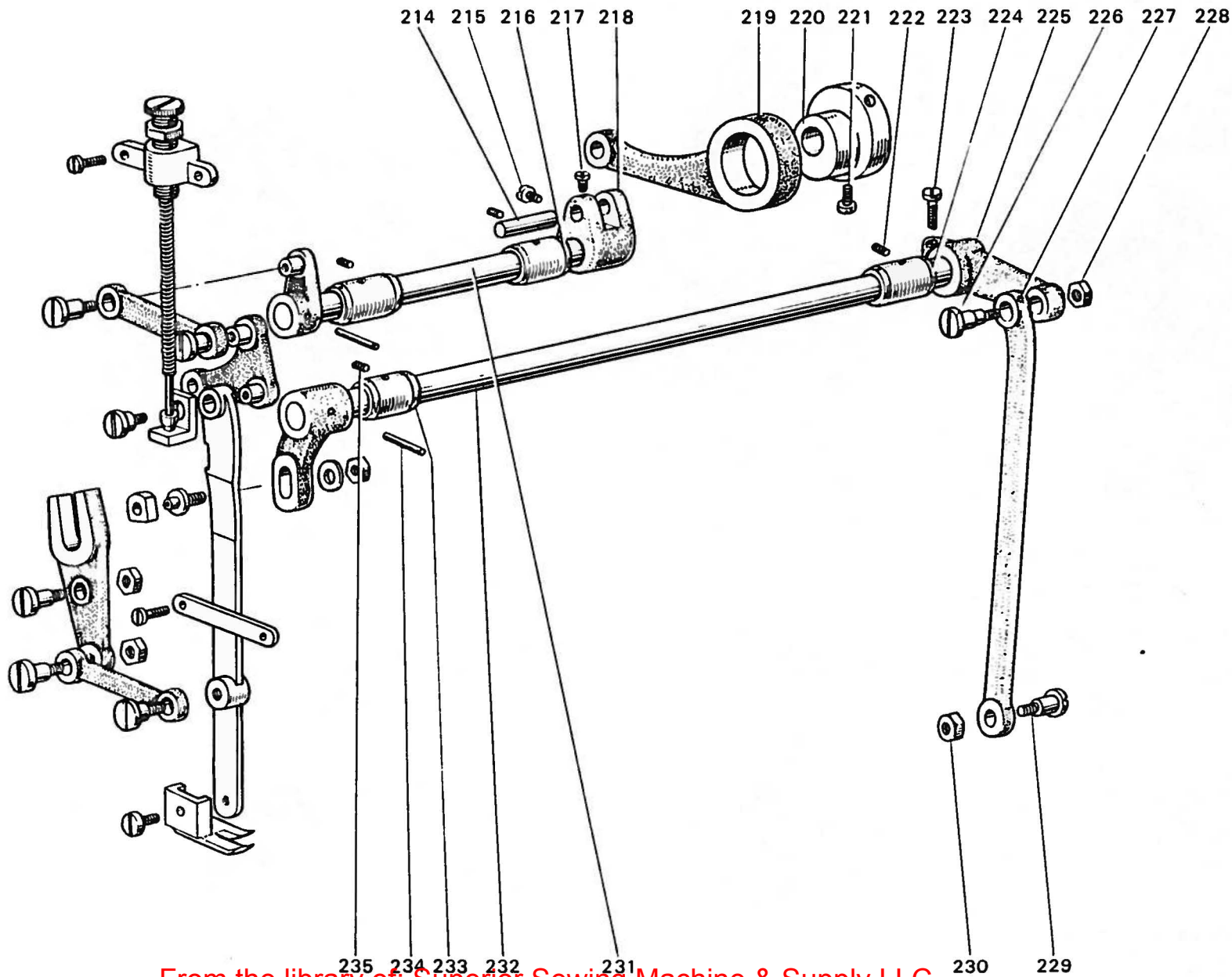





DY-253形 返し縫い機構 REVERSE LEVER MECHAISM

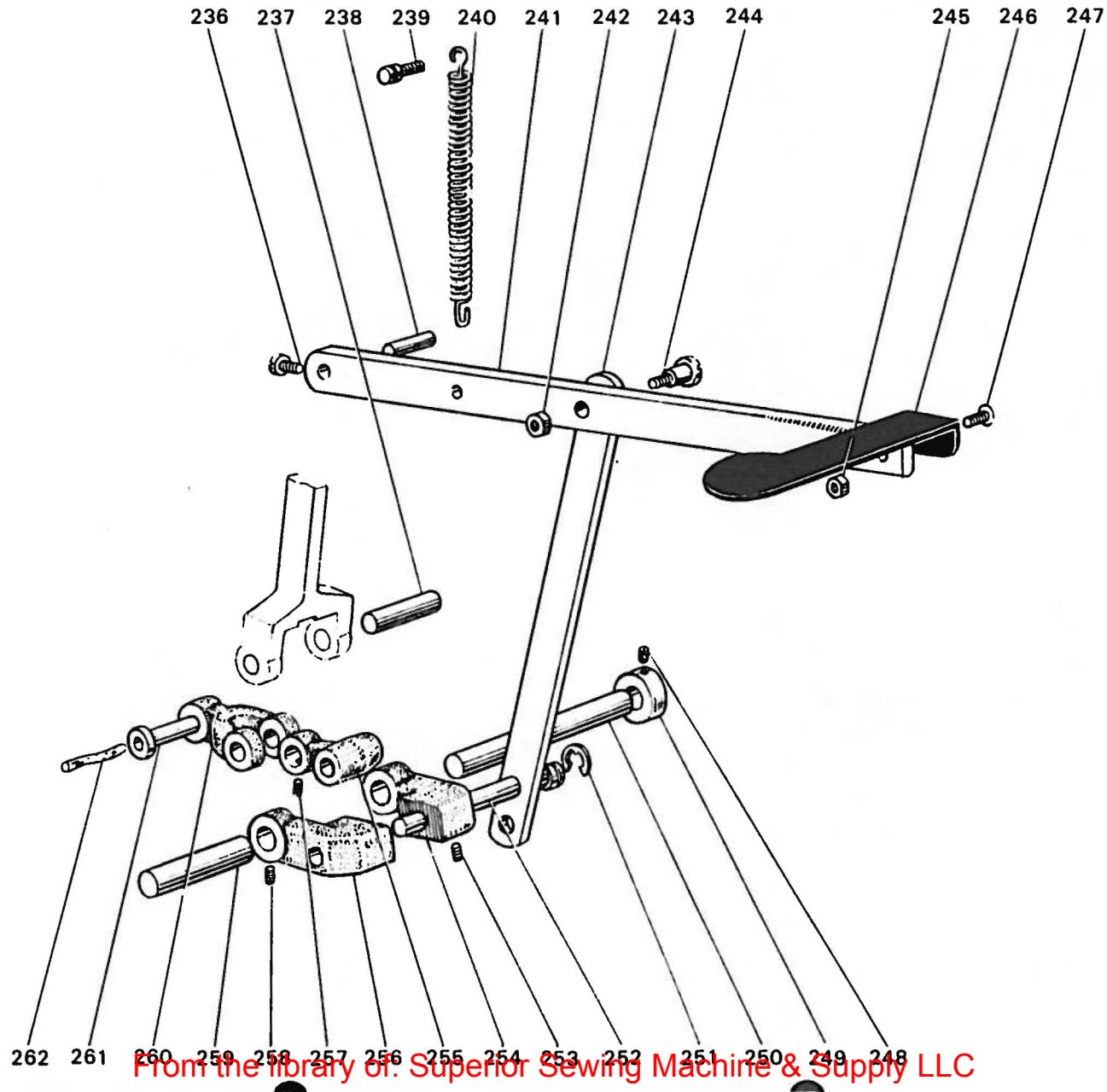

<DY-253形> 返し縫い機構 REVERSE LEVER MECHANISM

Fig. No.	サービス部品コード Part No.	資材コード Code No.	部 品 名	Name of Part	個 / 台 Amt. req					備 考 Remarks
236	M9 0903 002	B 509065	平 ネ ジ 9/64(40)×6.5	Screw for Fig.241						
237	M9 0703 060	W502921	ピ ン 7.94φ×29	Pin						
238	M9 0604 060	W502791	ピ ン 6.35φ×20	Pin for Fig.241						
239	M9 1101 030	W502032	バネ掛ケピン 11/64(40)×19	Spring guide pin						
240	MG 23C0 572	W461011	ツル巻バネ	Spring						
241	MG 23C0 322	W461010	返し縫イテコ	Reverse stitch lever						
242	M9 1502 045	W501883	ナ ッ ト 15/64(28)×4	Nut						
243	MG 23C0 953	W459357-01	運 結 板	Reverse stitch lever connecting Plate						
244	M9 1506 015	W501246	段付平ネジ 15/64(28)×16	Screw						
245	M9 1202 045	W500001	ナ ッ ト 3/16(28)×4	Nut						
246	MN 15A0 321	W459355-01	返し縫イ板	Reverse stitch lever plate						
247	M9 1201 010	W501934	皿 ネ ジ 3/16(28)×10	Lever plate screw						
248	M9 1506 001	B 509087	頭ナシ止メネジ 15/64(28)×7	Screw						
249	MM 11A0 352	W446142-01	カ ラ ー	Collar						
250	MG 23C0 320	W459373-01	返し縫イ軸	Reverse stitch shaft						
251	M9 0507 065	W465218	E 形 止 め 輪 7	E shape stop ring						
252	MG 23C0 454	W502780	軸	Pin for Fig.254						
253	M9 1506 001	B 509087	頭ナシ止メネジ 15/64(28)×7	Screw						
254	MN 15A0 323	W461018-01	返し縫イ腕	Reverse stitch crank(right)						
255	MN 15A0 886	W460582	揺 動 腕	Bell crank						
256	MN 15A0 323	W461018-01	返し縫イ腕	Reverse stitch crank(left)						
257	M9 1109 001	W500985	頭ナシ止メネジ 11/64(40)×6.6	Screw for Fig.255						
258	M9 1202 001	W500151	頭ナシ止メネジ 3/16(28)×6	Screw for Fig.256						
259	M9 0903 060	W461064	ピ ン 9.53φ×22	Pin for Fig.256						
260	MN 15A0 910	W460584	リ ン ク	Connecting link						
261	M9 0707 063	W501015	ピ ン 7.94φ×22.5	Pin for Fig.260						
262			油 ヒ モ	Oil wick						



DY-253形 押え上げ機構 PRESSER FOOT MECHANISM

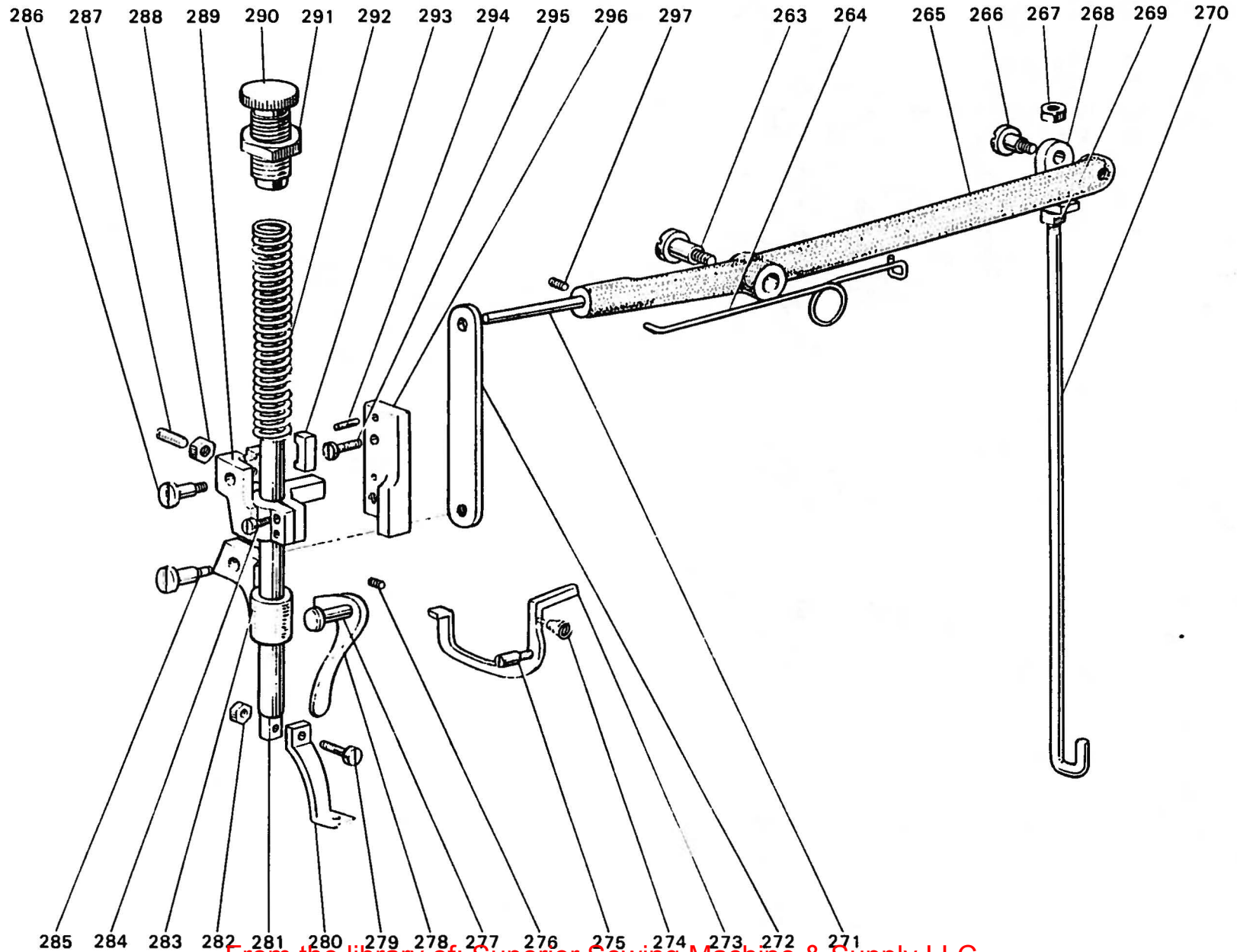

<DY-253形> 押え上げ機構 PRESSER FOOT MECHANISM

Fig. No.	サービス部品コード Part No.	資材コード Code No.	部 品 名	Name of Part	個 / 台 Amt. req					備 考 Remarks
263	M9 1551 016	B 503843	段付丸平ネジ 15/64(24)×30	Screw for Fig.265						
264	MG 23C0 729	W459375-01	ヒネリバネ	Spring for Fig.265						
265		W322771-01	ヒキ上ゲテコ	Knee lifter lifting lever link						
266	M9 1505 016	B 509176-02	段付丸平ネジ 15/64(28)×10	Screw for Fig.269						
267	M9 1251 045	B 509177-02	ナ ッ ト 3/16(32)×3	Nut for Fig.266						
268	MG 23C0 591	W461007-01	テ コ 接 手	Knee lifter rock shaft						
269	M9 1251 045	B 509177-02	ナ ッ ト 3/16(32)×3	Nut for Fig.270						
270	MG 23C0 593	W457521-01	テコ引キ棒	Lifting lever connecting rod						
271	M9 0605 060	W461006-01	ヒキ上ゲピン 6φ×60	Knee lifter lever pin						
272	MG 23C0 720	W502926	ヒキ上ゲ板	Knee lifting lever plate						
273	MG 23C0 220	W456595-01	上糸ユルメ	Thread tension releasing guide						
274	MF 10A2 245	B 409092-01	円 錐 バ ネ	Spring for Fig.273						
275	M9 0903 033	W459391	ピ ン ネ ジ 9/64(40)×12	Screw for Fig.273						
276	M9 1508 001	B 509088	頭ナシ止メネジ 15/64(28)×8	Set screw for Fig.278						
277	M9 0704 063	B 503977-02	押え上げピン 7φ×19	Presser bar lifter pin						
278	MG 23C0 252	W457532-01	押 エ 上 ゲ	Presser bar lifter						
279	M9 1112 002	W501889	平 ネ ジ 11/64(40)×12	Screw for Fig.280						
280	MG 23C0 256	W457548-01	押 エ 足	Presser foot						
281	MG 23C0 262	W457528-01	押 エ 棒	Presser bar						
282	M9 1106 045	W500698	ナ ッ ト 11/64(40)×3	Nut for Fig.279						
283	MG 23C0 475	W457531-01	スベリ上ゲ	Presser bar lifter bracket						
284	M9 1203 002	B 509178	平 ネ ジ 3/16(28)×15	Screw for Fig.289						
285	M9 1251 015	B 509180	段付平ネジ 3/16(32)×6	Screw for Fig.283						
286	M9 1210 002	W501247	平 ネ ジ 3/16(28)×10	Screw for Fig.289						
287	M9 1111 001	B 503852	頭ナシ止メネジ 11/64(40)×10	Screw for Fig.289						
288	M9 1103 045	W501528	ナ ッ ト 11/64(40)×3	Nut for Fig.287						
289	MG 23C0 265	W457529-01	押エ棒ダキ	Presser bar holder						
290	M9 4001 035	W457540-01	押エ調節ネジ 5/8(28)×49	Presser regulating thumb screw						
291	M9 4001 045	W461008-01	ナ ッ ト 5/8(28)×6	Nut for Fig.290						
292	MG 23C0 259	W457541-01	押 エ バ ネ	Presser spring						
293	MG 23C0 751	W502726	摺 動 子	Presser bar slide						
294	M9 0304 060	W501874	ピ ン 3φ×12	Pin for Fig.296						
295	M9 1110 002	W500294	平 ネ ジ 11/16(40)×8	Screw for Fig.296						
296	MG 23C0 263	W457533-01	押エ棒ダキ案内	Presser bar holder guide						
297	M9 1508 001	B 509088	頭ナシ止メネジ 15/64(28)×7	Screw for Fig.265						



DY-253形 給油機構 OIL LUBRICATION MECHANISM

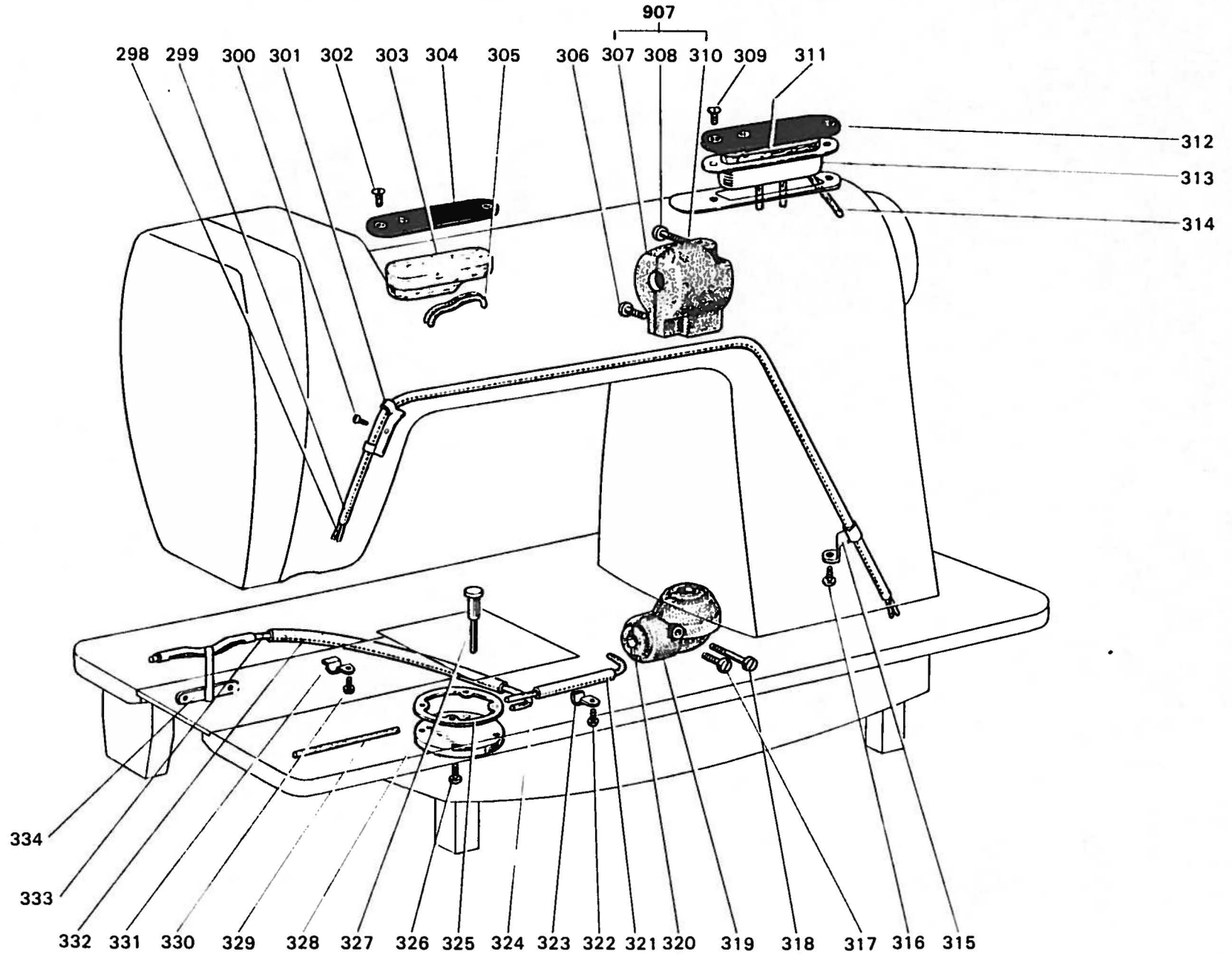

<DY-253形> 給油機構 OIL LUBRICATION MECHANISM

Fig No.	サービス部品コード Part No.	資材コード Code No.	部 品 名	Name of Part	個 / 台 Amt. req					備 考 Remarks
298		W444134	毛 糸	Oil wick						
299	MF 10AO 731	W446232	ビニールパイプ	Oil pipe						
300	M9 1110 002	W500294	平 ネ ジ 11/64(40)×8	Screw for Fig.301						
301	MG 23C0 689	W461024	パイプホルダ	pipe holder						
302	M9 0906 011	B 509269	丸 皿 ネ ジ 9/64(40)×7	Screw for Fig.304						
303	MF 60A4 740	W500905	フ ェ ル ト	Oil felt						
304	MG 23C0 742	W445619	フ タ	Oil reservoir cover						
305	MF 10E2 148	W464039	油 ヒ モ 2.5φ×100	Oil wick						
306	M9 1852 002	W501146	平 ネ ジ 9/32(20)×16	Screw for Fig.307						Fig.No.907ニ含ム
907	MG 23E0 711		歯 車 箱 上(組)	Arm shaft bevel gear box complete(upper)						
307		W456599	歯 車 箱(上左)	Arm shaft bevel gear box(left)						Fig.No907ニ含ム
308	M9 1503 002	B 504000	平 ネ ジ 15/64(28)×5	Screw for Fig.307						
309	M9 0906 011	B 509269	丸 皿 ネ ジ 9/64(40)×7	Screw for Fig.312						
310		W457500	歯 車 箱(上右)	Arm shaft bevel gear box(right)						Fig.No.907ニ含ム
311	MF 60A4 740	W500905	フ ェ ル ト	Oil felt						
312	MG 23C0 742	W445619	フ タ	Oil reservoir cover						
313	MG 23C0 139	W447200-2	油 タ ン ク	Oil reservoir						
314	MF 10E2 148	W464039	油 ヒ モ 2.5φ×100	Oil wick						
315	MF 60A1 689	W444233	パイプホルダー	Oil pipe holder						
316	M9 1110 002	W500294	平 ネ ジ 11/64(40)×8	Screw for Fig.315						
908	MG 23E0 712		歯 車 箱 下(組)	Hook shaft bevel gear box complete(lower)						
317	M9 1852 002	W501146	平 ネ ジ 9/32(20)×16	Set screw for Fig.319						Fig.No.908ニ含ム
318	M9 1503 002	B 504000	平 ネ ジ 15/64(28)×5	Set screw for Fig.319						
319		W457505	歯 車 箱(下右)	Hook shaft bevel gear box(right)						Fig.No.908ニ含ム
320		W457504	歯 車 箱(下左)	Hook shaft bevel gear box(left)						"
321	MF 10AO 731	W446232	ビニールパイプ	Oil pipe						
322	M9 1110 002	W500294	平 ネ ジ 11/64(40)×8	Set screw for Fig.323						
323	MF 10AO 689	W444230	パイプホルダー	Oil pipe holder						
324	MF 10E2 148	W444138	油 ヒ モ 2.5φ×240	Oil wick						
325	MN 10A1 691	W444122-1	パ ッ キ ン	"O"ring						
326	M9 1118 002	B 509061	平 ネ ジ 11/64(40)×10	Set screw for Fig.327						
327	MG 23C0 250	W502927	オイルゲージ	Oil gauge						
328	MN 10A3 742	W444237-1	フ タ	Cover						
329	MF 10E2 148	W444138	油 ヒ モ 2.5φ×240	Oil wick						
330	M9 1110 002	W500294	平 ネ ジ 11/64(40)×8	Set screw for Fig.331						
331	MF 10AO 689	W444230	パイプホルダー	Oil pipe holder						
332	MF 10AO 731	W446232	ビニールパイプ	Oil pipe						
333	MF 10AO 148	W444138	油 ヒ モ 2.φ×240	Oil wick						
334	MG 23C0 147	W461023	油 ヒ モ 支 エ	Oil pipe holder						



DY-253形 付属品(付属品箱) ACCESSORIES BOX

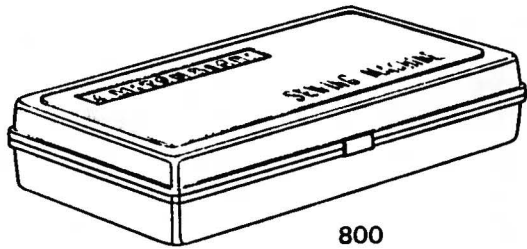

800

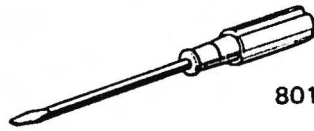

801

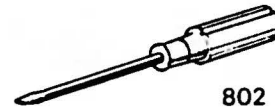

802



803



804

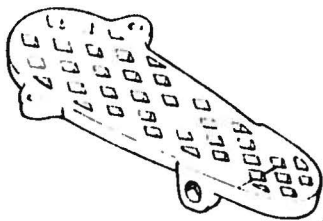

823

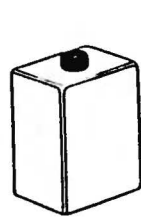

805



806



807

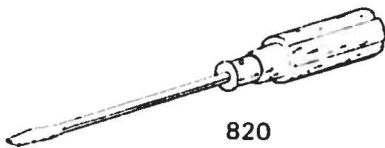

820

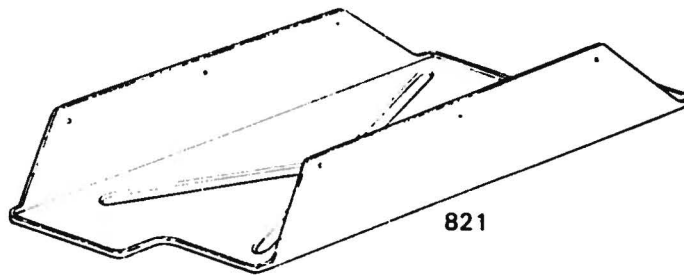

821

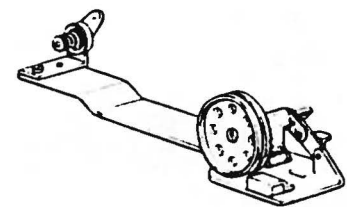

822

